

RENEWAL PARTS



IC2820-A100 RELAYS

Forms A and B

NOTE:—When ordering parts for a form of the relay not covered by this bulletin, give reference number, description of part, complete nameplate reading, and above bulletin (GEF) number. Do not use catalog number when form for which the parts are needed is not covered by the bulletin.

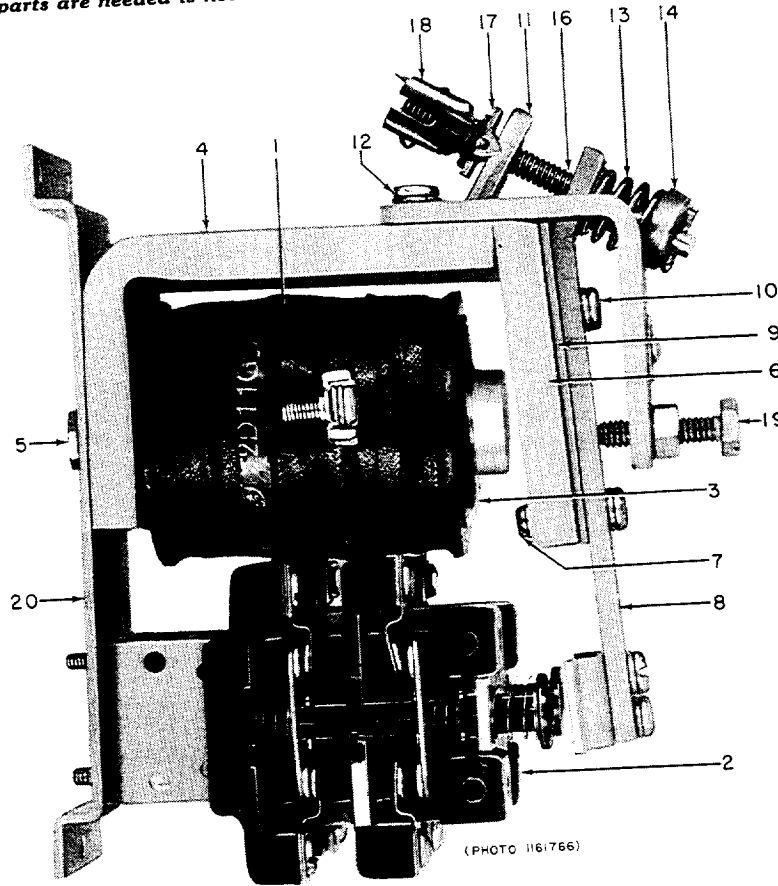

IC2820-A100B Relay

PARTS RECOMMENDED FOR NORMAL STOCK

Ref. No.	No. Req. for IC2820-A100-		Catalog Number	Description
	A	B		
1	1	1	-----	Operating coil (see table on page 2)
	Δ	Δ	-----	Set of switch unit contacts (see table on pages 2 thru 8)
13	1	1	235184	Compression spring for armature

Δ A quantity of one set is required for each switch unit.

When ordering renewal parts, give quantity, catalog number, description of each item required, and complete nameplate reading.

GENERAL  ELECTRIC

IC2820-A100 RELAYS

Ref. No. 1 - OPERATING COILS - 1 Required

NOTE:- The operating coil is identified by the number following the form letter in the IC designation.

Example:- IC2820-A100-A-2-B requires operating coil number No. 2, Cat. No. 22D11G25.

Coil No.	Catalog Number	Coil No.	Catalog Number	Coil No.	Catalog Number	Coil No.	Catalog Number	Coil No.	Catalog Number
2	22D11G25	37	22D11G86	73	Δπ 2693247P4	232	§22D13G78	263	3241953
3	22D11G26	38	22D11G27	74	Δπ 3621781P1	233	§22D13G79	264	22D11G99
4	22D11G49	39	22D11G67	75	22D11G167	234	§22D13G80	265	3021083
5	22D11G50	40	22D11G68	76	Δπ 3899912G3	235	§22D13G11	266	3243144
6	22D11G61	41	22D11G54	77	§22D13G85	236	§22D13G81	267	3240015
7	22D11G75	42	22D11G75	78	22D11G43	237	§22D13G29	268	22D185G2
8	22D11G67	43	22D11G88	202	§22D13G2	238	§22D13G35	269	22D185G3
9	22D11G44	44	22D11G95	203	§22D13G4	239	Δ◇9348300G5	270	3021124
10	22D11G59	45	22D11G61	204	§¶22D13G13	240	Δ◇9348300G4	271	3241294
11	22D11G29	46	22D11G57	205	§¶22D13G13	241	Δ◇9348300G11	276	22D11G205
12	22D11G136	47	22D11G58	206	§22D13G32	242	Δ◇9348300G8	277	22D11G206
13	22D11G45	48	22D11G110	207	§22D13G39	243	Δ◇9348300G9	278	22D11G18
14	22D11G46	49	22D11G74	208	§22D13G5	244	Δ◇9348300G17	279	22D13G63
15	22D11G128	50	22D11G76	209	§22D13G38	245	Δ◇9348300G15	280	22D11G5
16	22D11G69	51	22D11G96	210	§22D13G3	246	Δ◇9348300G21	281	22D11G207
17	22D11G47	52	22D11G100	211	§22D13G8	247	Δ◇9348300G6	282	22D11G211
18	22D11G60	53	22D11G77	212	§22D13G42	248	Δ◇9348300G7	283	22D11G209
19	22D11G48	54	Δ%2693247P2	213	‡22D42G3	249	Δ◇9348300G5	284	22D11G210
20	22D11G168	55	Δ%2693247P1	214	§22D13G7	250	Δ◇9348300G4	286	22D11G212
21	22D11G62	56	22D11G132	215	§22D13G19	251	Δ◇9348300G11	290	Δφ9348300G5
22	22D11G63	57	Δ◇394B300G5	216	§22D13G13	252	Δ◇9348300G8	291	Δφ9348300G4
23	22D11G208	58	Δ2693247P2	217	§¶22D13G13	253	Δ◇9348300G9	292	Δφ9348300G11
24	22D11G43	61	Δ%2693247P2	218	§22D13G50	254	Δ◇9348300G19	293	Δφ9348300G8
29	22D11G26	62	Δπ 2693247P13	219	§22D13G33	255	Δ◇9348300G20	294	Δφ9348300G9
30	22D11G46	63	Δπ 2693247P7	220	§22D13G15	256	Δ◇9348300G26	295	Δφ978B713G1
31	22D11G45	64	Δπ 5196302G1	221	§22D13G82	257	Δ◇9348300G13	296	Δφ978B713G2
32	22D11G29	67	Δπ 2693247P2	222	§22D13G83	258	Δφ9348300G11	297	Δφ978B713G3
33	22D11G59	68	Δπ 2693247P7	225	22D13G20	260	22D11G204	298	Δ◇9348300G12
34	22D11G55	69	Δ5196302G2	229	§22D13G38	261	3323116	299	§22D13G84
35	22D11G71	71	22D11G4	230	§22D13G32	262	3241960	300	Δ◇9348300G6
36	22D11G70	72	22D11G56	231	§22D13G10				

Δ Edgewise wound copper.

% Requires insulation tube Cat. No. 5186178P2 and 2 spool flanges Cat. No. 6902006.

◇ Requires frame insulation Cat. No. 2446601.

π Requires insulation tube Cat. No. 5186178P2 and 2 spool flanges Cat. No. 1432114.

§ Requires copper jacket Cat. No. 2494629.

¶ Connected in series with resistor unit. Cat. No. of coil does not include resistor unit. When ordering resistor unit give number stamped on unit.

‡ Requires copper jacket Cat. No. 4953090G1.

φ Requires frame insulation Cat. No. 119A5972P1.

Ref.No. 2 - SWITCH UNITS

NOTE:- The switch unit is identified by the letter following the coil number in the IC designation.

Example:- IC2820-A100-A-2-B requires switch unit letter B, Cat. No. IC2956A100B.

Switch Unit Letter	Switch Units with Mounting Parts and Operating Arm	Switch Unit Only		†Set of Contacts for 1 Switch Unit	# Position of Switch Unit					
	Catalog Number	Catalog Number	No. Req.	Catalog Number	1	2	3	4	5	6
FOR IC2820-A100-A										
B	IC2956A100B	IC2956A200H	1	6960053G2	X	-	-	-	-	-
C	IC2956A100C	IC2956A200G	1	6960053G2	X	-	-	-	-	-

† Includes movable and stationary contacts with springs and contact-holding screws.

Position of the switch unit is determined by counting from the left-hand side.

IC2820-A100 RELAYS

Ref. No. 2 - SWITCH UNITS

Switch Unit Letter	Switch Units with Mounting Parts and Operating Arm	Switch Unit Only		†Set of Contacts for 1 Switch Unit	# Position of Switch Unit					
		Catalog Number	Catalog Number	Catalog Number	1	2	3	4	5	6

FOR IC2820-A100-A

D	IC2956A100D	IC2956A200B	1	6960053G3	X	-	-	-	-	-
E	IC2956A100E	IC2956A200C	1	6960053G3	X	-	-	-	-	-
F	IC2956A100F	IC2956A200A	1	6960053G3	X	-	-	-	-	-
G	IC2956A100G	IC2956A200AG	1	6960053G3	X	-	-	-	-	-
R	IC2956A100R	IC2956A200AH	1	6960053G23	X	-	-	-	-	-
DB	IC2956A100DB	IC2956A200AE	1	6960053G23	X	-	-	-	-	-
DC	IC2956A100DC	IC2956A200AD	1	6960053G22	X	-	-	-	-	-
DD	IC2956A100DD	IC2956A200AB	1	6960053G22	X	-	-	-	-	-
DE	IC2956A100DE	IC2956A200AC	1	6960053G22	X	-	-	-	-	-
DF	IC2956A100DF	IC2956A200AA	1	6960053G3	X	-	-	-	-	-
HB	IC2956A100HB	IC2956A200AG	1	6960053G25	X	-	-	-	-	-
HC	IC2956A100HC	IC2956A205E	1	6960053G25	X	-	-	-	-	-
HD	IC2956A100HD	IC2956A205D	1	6960053G24	X	-	-	-	-	-
HE	IC2956A100HE	IC2956A205B	1	6960053G24	X	-	-	-	-	-
HF	IC2956A100HF	IC2956A205A	1	6960053G24	X	-	-	-	-	-

FOR IC2820-A100-B

B	IC2956A101B	IC2956A200H	1	6960053G2	X	-	-	-	-	-
C	IC2956A101C	IC2956A200G	1	6960053G2	X	-	-	-	-	-
D	IC2956A101D	IC2956A200B	1	6960053G3	X	-	-	-	-	-
E	IC2956A101E	IC2956A200C	1	6960053G3	X	-	-	-	-	-
F	IC2956A101F	IC2956A200A	1	6960053G3	X	X	-	-	-	-
G	IC2956A101G	IC2956A200B	2	6960053G3	X	-	-	-	-	-
H	IC2956A101H	{ IC2956A200C	1	6960053G3	X	-	-	-	-	-
		{ IC2956A200B	1	6960053G3	-	X	-	-	-	-
J	IC2956A101J	IC2956A200C	2	6960053G3	X	X	-	-	-	-
K	IC2956A101K	{ IC2956A200C	1	6960053G3	X	-	-	-	-	-
		{ IC2956A200A	1	6960053G3	-	X	-	-	-	-
L	IC2956A101L	IC2956A200A	2	6960053G3	X	X	-	-	-	-
M	IC2956A101M	IC2956A200U	1	6960053G3	X	-	-	-	-	-
N	IC2956A101N	IC2956A200R	2	6960053G3	X	X	-	-	-	-
P	IC2956A101P	IC2956A200AG	1	6960053G3	X	X	-	-	-	-
Q	IC2956A101Q	IC2956A200AG	2	6960053G3	X	-	-	-	-	-
R	IC2956A101R	IC2956A200AH	1	6960053G3	X	X	-	-	-	-
S	IC2956A101S	IC2956A200U	2	6960053G3	X	X	X	-	-	-
AB	IC2956A101AB	IC2956A200B	3	6960053G3	X	X	X	-	-	-
AD	IC2956A101AD	{ IC2956A200C	1	6960053G3	X	-	-	-	-	-
		{ IC2956A200B	2	6960053G3	-	X	X	-	-	-
AE	IC2956A101AE	{ IC2956A200C	2	6960053G3	X	X	-	-	-	-
		{ IC2956A200B	1	6960053G3	-	-	X	-	-	-
AF	IC2956A101AF	IC2956A200C	3	6960053G3	X	X	X	-	-	-
AG	IC2956A101AG	{ IC2956A200C	2	6960053G3	X	X	-	-	-	-
		{ IC2956A200A	1	6960053G3	-	-	X	-	-	-
AH	IC2956A101AH	IC2956A200C	1	6960053G3	X	-	-	-	-	-
AJ	IC2956A101AJ	{ IC2956A200A	2	6960053G3	X	X	X	-	-	-
		{ IC2956A200A	3	6960053G3	X	-	-	-	-	-
AK	IC2956A101AK	IC2956A200AJ	1	6960053G3	X	-	-	-	-	-
AL	IC2956A101AL	{ IC2956A200AH	2	6960053G3	-	X	X	-	-	-
		{ IC2956A200C	3	6960053G3	X	X	X	-	-	-
BB	IC2956A101BB	IC2956A200AH	2	6960053G3	X	X	-	-	-	-
		{ IC2956A200B	2	6960053G3	-	-	X	X	-	-
		{ IC2956A200C	3	6960053G3	X	X	X	-	-	-
BC	IC2956A101BC	IC2956A200B	1	6960053G3	-	-	-	X	-	-
BD	IC2956A101BD	IC2956A200C	4	6960053G3	X	X	X	X	-	-

† Includes movable and stationary contacts with springs and contact-holding screws.
 # Position of the switch unit is determined by counting from left-hand side.

IC2820-A100 RELAYS

Ref. No. 2 - SWITCH UNITS

Switch Unit Letter	Switch Units with Mounting Parts and Operating Arm	Switch Unit Only		†Set of Contacts for 1 Switch Unit	# Position of Switch Unit						
		Catalog Number	Catalog Number		No. Req.	Catalog Number	1	2	3	4	5
FOR IC2820-A100-B											
BE	IC2956A101BE	{ IC2956A200C		3	6960053G3	X	X	X	-	-	-
		{ IC2956A200A		1	6960053G3	-	-	-	X	-	-
BF	IC2956A101BF	{ IC2956A200C		2	6960053G3	X	X	-	-	-	-
		{ IC2956A200A		2	6960053G3	-	-	X	X	-	-
BG	IC2956A101BG	{ IC2956A200C		1	6960053G3	X	-	-	-	-	-
		{ IC2956A200A		3	6960053G3	-	X	X	X	-	-
BH	IC2956A101BH	IC2956A200A		4	6960053G3	X	X	X	X	-	-
BJ	IC2956A101BJ	{ IC2956A200R		2	6960053G3	X	X	-	-	-	-
		{ IC2956A200U		2	6960053G3	-	-	X	X	-	-
BK	IC2956A101BK	IC2956A200B		4	6960053G3	X	X	X	X	-	-
CB	IC2956A101CB	IC2956A200C		4	6960053G3	X	X	X	X	-	-
		IC2956A200B		1	6960053G3	-	-	-	-	-	X
CC	IC2956A101CC	IC2956A200C		5	6960053G3	X	X	X	X	-	X
CD	IC2956A101CD	{ IC2956A200C		4	6960053G3	X	X	X	X	-	-
		{ IC2956A200A		1	6960053G3	-	-	-	-	-	X
CE	IC2956A101CE	{ IC2956A200C		3	6960053G3	X	X	X	-	-	-
		{ IC2956A200A		2	6960053G3	-	-	-	X	-	X
CF	IC2956A101CF	{ IC2956A200C		2	6960053G3	X	X	-	-	-	-
		{ IC2956A200A		3	6960053G3	-	-	X	X	-	X
CG	IC2956A101CG	{ IC2956A200C		1	6960053G3	X	-	-	-	-	-
		{ IC2956A200A		4	6960053G3	-	X	X	X	-	X
CH	IC2956A101CH	IC2956A200A		5	6960053G3	X	X	X	X	-	X
CJ	IC2956A101CJ	IC2956A200C		6	6960053G3	X	X	X	X	X	X
CK	IC2956A101CK	{ IC2956A200C		5	6960053G3	X	X	X	X	X	-
		{ IC2956A200A		1	6960053G3	-	-	-	-	-	X
CL	IC2956A101CL	{ IC2956A200C		4	6960053G3	X	X	X	X	-	-
		{ IC2956A200A		2	6960053G3	-	-	-	-	X	X
CM	IC2956A101CM	{ IC2956A200C		3	6960053G3	X	X	X	-	-	-
		{ IC2956A200A		3	6960053G3	-	-	-	X	X	X
CN	IC2956A101CN	{ IC2956A200C		2	6960053G3	X	X	-	-	-	-
		{ IC2956A200A		4	6960053G3	-	-	X	X	X	X
CP	IC2956A101CP	{ IC2956A200C		1	6960053G3	X	-	-	-	-	-
		{ IC2956A200A		5	6960053G3	-	X	X	X	X	X
CQ	IC2956A101CQ	IC2956A200A		6	6960053G3	X	X	X	X	X	X
CR	IC2956A101CR	{ IC2956A200AJ		3	6960053G3	X	X	X	-	-	-
		{ IC2956A200AH		2	6960053G3	-	-	-	X	X	-
DB	IC2956A101DB	IC2956A200AE		1	6960053G23	X	-	-	-	-	-
DC	IC2956A101DC	IC2956A200AD		1	6960053G23	X	-	-	-	-	-
DD	IC2956A101DD	IC2956A200AB		1	6960053G22	X	-	-	-	-	-
DE	IC2956A101DE	IC2956A200AC		1	6960053G22	X	-	-	-	-	-
DF	IC2956A101DF	IC2956A200AA		1	6960053G22	X	-	-	-	-	-
DG	IC2956A101DG	IC2956A200AB		2	6960053G22	X	X	-	-	-	-
DH	IC2956A101DH	{ IC2956A200AC		1	6960053G22	X	-	-	-	-	-
		{ IC2956A200AB		1	6960053G22	-	X	-	-	-	-
DJ	IC2956A101DJ	IC2956A200AC		2	6960053G22	X	X	-	-	-	-
DK	IC2956A101DK	{ IC2956A200AC		1	6960053G22	X	-	-	-	-	-
		{ IC2956A200AA		1	6960053G22	-	X	-	-	-	-
DL	IC2956A101DL	IC2956A200AA		2	6960053G22	X	X	-	-	-	-
DM	IC2956A101DM	{ IC2956A200AC		1	6960053G22	X	-	-	-	-	-
		{ IC2956A200C		1	6960053G3	-	X	-	-	-	-
DN	IC2956A101DN	{ IC2956A200AB		1	6960053G22	X	-	-	-	-	-
		{ IC2956A200B		1	6960053G3	-	X	-	-	-	-
DP	IC2956A101DP	{ IC2956A200AA		1	6960053G22	X	-	-	-	-	-
		{ IC2956A200A		1	6960053G3	-	X	-	-	-	-
EB	IC2956A101EB	IC2956A200AB		3	6960053G22	X	X	X	-	-	-
ED	IC2956A101ED	{ IC2956A200AC		1	6960053G22	X	-	-	-	-	-
		{ IC2956A200AB		2	6960053G22	-	X	X	-	-	-

† Includes movable and stationary contacts with springs and contact-holding screws.
 # Position of the switch unit is determined by counting from the left-hand side.

IC2820-A100 RELAYS

Ref. No. 2 - SWITCH UNITS

Switch Unit Letter	Switch Units with Mounting Parts and Operating Arm	Switch Unit Only		†Set of Contacts for 1 Switch Unit	# Position of Switch Unit					
		Catalog Number	No. Req.		Catalog Number	1	2	3	4	5
FOR IC2820-A100-B										
EE	IC2956A101EE	{ IC2956A200AC	2	6960053G22	X	X	-	-	-	-
EF	IC2956A101EF	{ IC2956A200AB	1	6960053G22	-	-	X	-	-	-
EG	IC2956A101EG	{ IC2956A200AC	3	6960053G22	X	X	X	-	-	-
EH	IC2956A101EH	{ IC2956A200AA	2	6960053G22	-	-	X	-	-	-
EJ	IC2956A101EJ	{ IC2956A200AC	1	6960053G22	X	X	X	-	-	-
FB	IC2956A101FB	{ IC2956A200AA	1	6960053G22	-	-	X	X	-	-
FC	IC2956A101FC	{ IC2956A200AC	2	6960053G22	X	X	X	-	-	-
FD	IC2956A101FD	{ IC2956A200AA	3	6960053G22	X	X	X	X	-	-
FE	IC2956A101FE	{ IC2956A200AC	2	6960053G22	-	-	X	X	-	-
FF	IC2956A101FF	{ IC2956A200AB	3	6960053G22	X	X	X	X	-	-
FG	IC2956A101FG	{ IC2956A200AC	1	6960053G22	-	-	X	X	-	-
FH	IC2956A101FH	{ IC2956A200AA	4	6960053G22	X	X	X	X	-	-
FJ	IC2956A101FJ	{ IC2956A200AC	2	6960053G22	X	X	X	X	-	-
GB	IC2956A101GB	{ IC2956A200AB	2	6960053G3	-	-	X	X	X	-
GC	IC2956A101GC	{ IC2956A200C	4	6960053G22	X	X	X	X	-	-
GD	IC2956A101GD	{ IC2956A200AC	1	6960053G22	-	-	X	X	X	-
GE	IC2956A101GE	{ IC2956A200AA	5	6960053G22	X	X	X	X	-	-
GF	IC2956A101GF	{ IC2956A200AC	4	6960053G22	-	-	X	X	X	-
GG	IC2956A101GG	{ IC2956A200AA	1	6960053G22	X	X	X	X	X	-
GH	IC2956A101GH	{ IC2956A200AC	3	6960053G22	X	X	X	X	X	-
GJ	IC2956A101GJ	{ IC2956A200AA	2	6960053G22	-	-	X	X	X	-
GK	IC2956A101GK	{ IC2956A200AC	3	6960053G22	X	X	X	X	X	-
GL	IC2956A101GL	{ IC2956A200AA	1	6960053G22	-	-	X	X	X	-
GM	IC2956A101GM	{ IC2956A200AC	4	6960053G22	X	X	X	X	X	-
GN	IC2956A101GN	{ IC2956A200AA	2	6960053G22	-	-	X	X	X	-
GP	IC2956A101GP	{ IC2956A200AC	3	6960053G22	X	X	X	X	X	-
GQ	IC2956A101GQ	{ IC2956A200AA	4	6960053G22	X	X	X	X	X	-
HB	IC2956A101HB	{ IC2956A205B	1	6960053G24	X	X	X	X	X	-
HC	IC2956A101HC	{ IC2956A205C	1	6960053G24	-	-	X	X	X	-
HD	IC2956A101HD	{ IC2956A205B	1	6960053G25	X	X	X	X	X	-
HE	IC2956A101HE	{ IC2956A205E	1	6960053G24	-	-	X	X	X	-
HF	IC2956A101HF	{ IC2956A205B	1	6960053G24	X	X	X	X	X	-
		{ IC2956A205D	1	6960053G25	-	-	X	X	X	-

† Includes movable and stationary contacts with springs and contact-holding screws.
 # Position of the switch unit is determined by counting from the left-hand side.

IC2820-A100 RELAYS

Ref. No. 2 - SWITCH UNITS

Switch Unit Letter	Switch Units with Mounting Parts and Operating Arm	Switch Unit Only		† Set of Contacts for 1 Switch Unit	# Position of Switch Unit					
		Catalog Number	Catalog Number		No. Req.	Catalog Number	1	2	3	4
FOR IC2820-A100-B										
HG	IC2956A101HG	{ IC2956A205B	1	6960053G24	X	-	-	-	-	-
		{ IC2956A200B	1	6960053G3	-	X	-	-	-	-
HH	IC2956A101HH	{ IC2956A205B	1	6960053G24	X	-	-	-	-	-
		{ IC2956A200C	1	6960053G3	-	X	-	-	-	-
HJ	IC2956A101HJ	{ IC2956A205B	1	6960053G24	X	-	-	-	-	-
		{ IC2956A200A	1	6960053G3	-	X	-	-	-	-
HK	IC2956A101HK	{ IC2956A205C	1	6960053G24	X	-	-	-	-	-
		{ IC2956A205A	1	6960053G24	-	X	-	-	-	-
HL	IC2956A101HL	{ IC2956A205C	1	6960053G24	X	-	-	-	-	-
		{ IC2956A205D	1	6960053G25	-	X	-	-	-	-
HM	IC2956A101HM	{ IC2956A205C	1	6960053G24	X	-	-	-	-	-
		{ IC2956A200B	1	6960053G3	-	X	-	-	-	-
HN	IC2956A101HN	{ IC2956A205C	1	6960053G24	X	-	-	-	-	-
		{ IC2956A200C	1	6960053G3	-	X	-	-	-	-
HP	IC2956A101HP	{ IC2956A205C	1	6960053G24	X	-	-	-	-	-
		{ IC2956A200A	1	6960053G3	-	X	-	-	-	-
HR	IC2956A101HR	{ IC2956A205E	1	6960053G25	X	-	-	-	-	-
		{ IC2956A200B	1	6960053G3	-	X	-	-	-	-
HS	IC2956A101HS	{ IC2956A205E	1	6960053G25	X	-	-	-	-	-
		{ IC2956A200C	1	6960053G3	-	X	-	-	-	-
HT	IC2956A101HT	{ IC2956A205E	1	6960053G25	X	-	-	-	-	-
		{ IC2956A200A	1	6960053G3	-	X	-	-	-	-
HU	IC2956A101HU	IC2956A205A	2	6960053G24	X	X	-	-	-	-
HV	IC2956A101HV	{ IC2956A205A	1	6960053G24	X	-	-	-	-	-
		{ IC2956A205D	1	6960053G25	-	X	-	-	-	-
HW	IC2956A101HW	{ IC2956A205A	1	6960053G24	X	-	-	-	-	-
		{ IC2956A200B	1	6960053G3	-	X	-	-	-	-
HY	IC2956A101HY	{ IC2956A205A	1	6960053G24	X	-	-	-	-	-
		{ IC2956A200C	1	6960053G3	-	X	-	-	-	-
JB	IC2956A101JB	{ IC2956A205A	1	6960053C24	X	-	-	-	-	-
		{ IC2956A200A	1	6960053G3	-	X	-	-	-	-
JC	IC2956A101JC	{ IC2956A205D	1	6960053G25	X	-	-	-	-	-
		{ IC2956A200B	1	6960053G3	-	X	-	-	-	-
JD	IC2956A101JD	{ IC2956A205D	1	6960053G25	X	-	-	-	-	-
		{ IC2956A200C	1	6960053G3	-	X	-	-	-	-
JE	IC2956A101JE	{ IC2956A205D	1	6960053G25	X	-	-	-	-	-
		{ IC2956A200A	1	6960053G3	-	X	-	-	-	-
KB	IC2956A101KB	IC2956A205A	3	6960053G24	X	X	X	-	-	-
KC	IC2956A101KC	{ IC2956A205A	2	6960053G24	X	X	-	-	-	-
		{ IC2956A205C	1	6960053G24	-	-	X	-	-	-
KD	IC2956A101KD	{ IC2956A205A	1	6960053G24	X	-	-	-	-	-
		{ IC2956A205C	2	6960053G24	-	X	X	-	-	-
KE	IC2956A101KE	IC2956A205C	3	6960053G24	X	X	X	-	-	-
KF	IC2956A101KF	{ IC2956A205C	2	6960053G24	X	X	-	-	-	-
		{ IC2956A205B	1	6960053G25	-	-	X	-	-	-
LB	IC2956A101LB	IC2956A205A	4	6960053G24	X	X	X	X	-	-
LC	IC2956A101LC	{ IC2956A205A	3	6960053G24	X	X	X	-	-	-
		{ IC2956A205C	1	6960053G24	-	-	-	X	-	-
LD	IC2956A101LD	{ IC2956A205A	3	6960053G24	X	X	X	-	-	-
		{ IC2956A205B	1	6960053G24	-	-	-	X	-	-
LE	IC2956A101LE	{ IC2956A205A	2	6960053G24	X	X	-	-	-	-
		{ IC2956A205C	1	6960053G24	-	-	X	-	-	-
		{ IC2956A205B	1	6960053G24	-	-	-	X	-	-
LF	IC2956A101LF	IC2956A205C	4	6960053G24	X	X	X	X	-	-
LG	IC2956A101LG	{ IC2956A205A	3	6960053G24	X	X	X	-	-	-
		{ IC2956A200A	1	6960053G3	-	-	-	X	-	-

† Includes movable and stationary contacts with springs and contact-holding screws.
 # Position of the switch unit is determined by counting from the left-hand side.

IC2820-A100 RELAYS

GEF-4112C

Ref. No. 2 - SWITCH UNITS

Switch Unit Letter	Switch Units with Mounting Parts and Operating Arm	Switch Unit Only		†Set of Contacts for 1 Switch Unit	# Position of Switch Unit					
	Catalog Number	Catalog Number	No. Req.	Catalog Number	1	2	3	4	5	6

FOR IC2820-A100-B

LH	IC2956A101LH	IC2956A205A	2	6960053G24	X	X	-	-	-	-
		IC2956A200A	2	6960053G3	-	-	X	X	-	-
LJ	IC2956A101LJ	IC2956A205A	2	6960053G24	X	X	-	-	-	-
		IC2956A200C	1	6960053G3	-	-	X	-	-	-
LK	IC2956A101LK	IC2956A200A	1	6960053G3	-	-	-	X	-	-
		IC2956A205A	2	6960053G24	X	X	-	-	-	-
LL	IC2956A101LL	IC2956A200C	2	6960053G3	-	-	X	X	-	-
		IC2956A205A	2	6960053G24	X	X	-	-	-	-
LM	IC2956A101LM	IC2956A200C	1	6960053G3	-	-	X	-	-	-
		IC2956A200B	1	6960053G3	-	-	-	X	-	-
LN	IC2956A101LN	IC2956A205A	2	6960053G24	X	X	-	-	-	-
		IC2956A200B	2	6960053G3	-	-	X	X	-	-
LP	IC2956A101LP	IC2956A205A	1	6960053G24	X	-	-	-	-	-
		IC2956A205C	1	6960053G24	-	X	-	-	-	-
LR	IC2956A101LR	IC2956A200A	1	6960053G3	-	-	X	-	-	-
		IC2956A200C	1	6960053G3	-	-	-	X	-	-
LS	IC2956A101LS	IC2956A205A	1	6960053G24	X	-	-	-	-	-
		IC2956A205C	1	6960053G24	-	X	-	-	-	-
LT	IC2956A101LT	IC2956A200C	1	6960053G3	-	-	X	-	-	-
		IC2956A200B	1	6960053G3	-	-	-	X	-	-
LU	IC2956A101LU	IC2956A205A	2	6960053G24	X	X	-	-	-	-
		IC2956A205C	2	6960053G24	-	-	X	X	-	-
LV	IC2956A101LV	IC2956A200A	2	6960053G3	X	X	-	-	-	-
		IC2956A200C	1	6960053G3	-	-	X	-	-	-
LW	IC2956A101LW	IC2956A200A	1	6960053G3	-	-	-	X	-	-
		IC2956A205C	2	6960053G24	X	X	-	-	-	-
LY	IC2956A101LY	IC2956A205C	2	6960053G24	X	X	-	-	-	-
		IC2956A200C	1	6960053G3	-	-	-	X	-	-
MB	IC2956A101MB	IC2956A200B	1	6960053G3	-	-	-	X	-	-
		IC2956A205A	1	6960053G24	X	-	-	-	-	-
MC	IC2956A101MC	IC2956A200A	3	6960053G3	-	X	X	X	-	-
		IC2956A205C	1	6960053G24	X	-	-	-	-	-
MD	IC2956A101MD	IC2956A205B	1	6960053G24	-	X	-	-	-	-
		IC2956A200A	2	6960053G3	-	-	X	X	-	-
ME	IC2956A101ME	IC2956A205C	2	6960053G24	X	X	-	-	-	-
		IC2956A200C	1	6960053G3	-	-	X	-	-	-
MF	IC2956A101MF	IC2956A200B	1	6960053G3	-	-	-	X	-	-
		IC2956A205C	1	6960053G24	X	-	-	-	-	-
MG	IC2956A101MG	IC2956A200C	2	6960053G3	-	X	X	-	-	-
		IC2956A200A	1	6960053G3	-	-	-	X	-	-
		IC2956A205B	2	6960053G24	X	X	-	-	-	-
		IC2956A200A	2	6960053G3	-	-	X	X	-	-

† Includes movable and stationary contacts with springs and contact-holding screws.
 # Position of the switch unit is determined by counting from the left-hand side.

IC2820-A100 RELAYS

Ref. No. 2 - SWITCH UNITS

Switch Unit Letter	Switch Units with Mounting Parts and Operating Arm	Switch Unit Only		† Set of Contacts for 1 Switch Unit	# Position of Switch Unit						
		Catalog Number	Catalog Number		No. Req.	Catalog Number	1	2	3	4	5
FOR IC2820-A100-B											
MH	IC2956A101MH	IC2956A205B		1	6960053G24	X	-	-	-	-	-
		IC2956A200C		2	6960053G3	-	X	X	-	-	-
		IC2956A200A		1	6960053G3	-	-	-	X	-	-
		IC2956A205C		1	6960053G24	X	-	-	-	-	-
MJ	IC2956A101MJ	IC2956A205B		1	6960053G24	-	X	-	-	-	-
		IC2956A200C		1	6960053G3	-	-	X	-	-	-
		IC2956A200A		1	6960053G3	-	-	-	X	-	-
						-	-	-	-	X	-

† Includes movable and stationary contacts with springs and contact-holding screws.

Position of the switch unit is determined by counting from the left-hand side.

SHIMS FOR ARMATURE

NOTE:- The shim is identified by the letter following the form letter in the IC designation.

Example:- IC2820-A100-A-B-2-E requires shim letter B, Cat. No. 2450533.

Shim Letter	Shim		Shim Letter	Shim	
	Catalog Number			Catalog Number	
A		†	F		8616834
B		2450533	R		8047765
C		5155942	X		2439592
D		5354689	Y		† 8047765
E		2451597			

† When specific time is required or special shim having no suffix letter is desired, specify shim Cat. No. and/or time setting required.

† 2 required.

COMPLETE LIST OF PARTS

Ref. No.	No. Req. for IC2820-A100-		Catalog Number	Description
	A	B		
3	1	1	1445721	Retaining washer for operating coil
4	1	1	2810489G1	Magnet frame with core
5	1	1	N26P21012B	Screw fastening magnet core to base (1/4 in. -20, 3/4 in. hex. hd. slot, pro. fin.)
6	1	1	9098152	Armature
7	2	2	N75P15006	Screw fastening shim to armature (8-32, 3/8 in. pan hd. brass)
8	1	-	1459971	Support for armature
8	-	1	576A123P1	Support for armature
9	1	1	2453389	Guide strip between armature and support
10	2	2	N144P16010C	Screw with lock washer fastening support and guide strip to armature
11	1	1	9034493P1	Bracket for armature
12	2	2	N144P16010C	Screw with lock washer fastening bracket to magnet frame
13	1	1	235134	Compression spring for armature
14	1	1	437972P1	Spring seat for compression spring
16	1	1	125A4875P1	Adjusting screw for compression spring
17	1	1	578A552P2	Support for adjusting screw
18	1	1	9196760P1	Lock nut for adjusting screw
19	1	1	N26P21016B	Stop screw for armature (1/4 in. -20, 1 in. hex. hd. slot, pro. fin.)
20	1	-	576A113P1	Base for relay
20	-	1	576A112P1	Base for relay

INDUSTRY CONTROL DEPARTMENT, GENERAL ELECTRIC COMPANY, SALEM, VA.