

RENEWAL PARTS



IC2812-B107 SYNCHRONOUS MOTOR FIELD CONTACTOR

Forms A, B, AA, and AB

BA-C A-D A-

NOTE:—When ordering parts for a form of the contactor not covered by this bulletin, give reference number, description of part, complete nameplate reading, and above bulletin (GEF) number. Do not use catalog number when form for which the parts are needed is not covered by the bulletin.

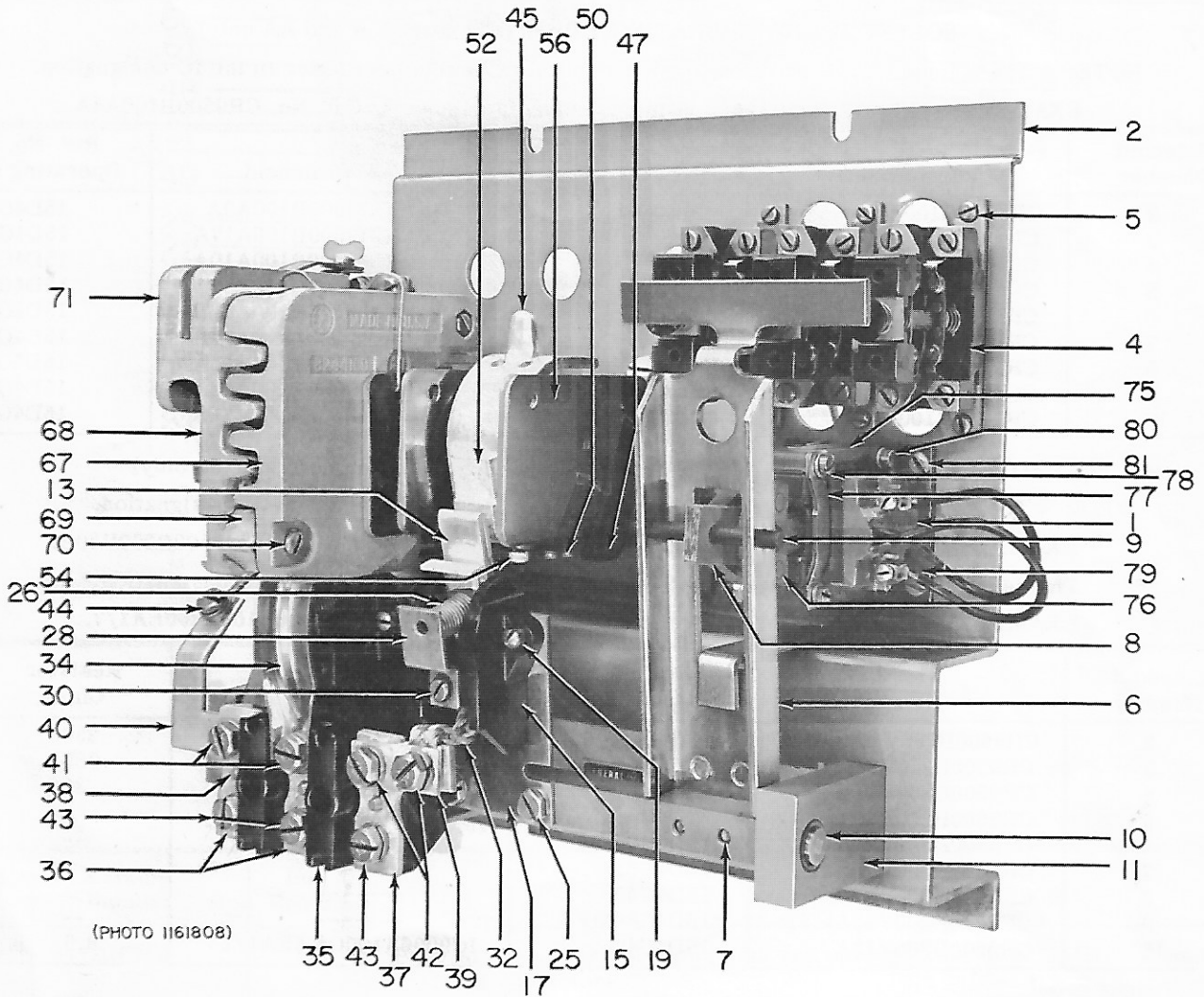

IC2812-B107A contactor (front view)

When ordering renewal parts, give quantity, catalog number, description of each item required, and complete nameplate reading.



IC2812-B107 SYNCHRONOUS MOTOR FIELD CONTACTORS

PARTS RECOMMENDED FOR NORMAL STOCK

Ref. No.	Catalog Number	No. Req'd.	Description
1	-----	1	Operating coil (see table below)
	6960053G3	3	Set of interlock switch unit contacts
13	8067076G2	2	Movable contact finger, normally open
14	8067076G1	1	Movable contact finger, normally open
52	8067063G1	2	Stationary contact, normally open
53	6973075G1	1	Stationary contact, normally closed
26	2416475	2	Compression spring for normally open movable contact finger
27	2418818	1	Compression spring for normally closed movable contact finger
21	2416475	1	Tension spring for operating plate
32	8068689G1	2	Shunt for normally open movable contact finger
33	117A7921G1	1	Shunt for normally closed movable contact finger
67	8244169P1	2	Arc chute side, right-hand, for normally open pole
68	8244169P2	2	Arc chute side, left-hand, for normally open pole
71	8650867P1	1	Arc chute, complete, for normally closed pole

SOLENOID AND OPERATING COILS (For Forms A and AA only)

NOTE: - The solenoid is identified by the number following the form letter in the IC designation.

EXAMPLE: - IC2812-B-107-A-4 requires solenoid number 4, Cat. No. CR9500B100A4A.

Solenoid Number	ΔSolenoid	Ref. No. 1 Operating Coil	Solenoid Number	ΔSolenoid	Ref. No. 1 Operating Coil
2	CR9500B100A2A	15D4G2	11	CR9500B100A9A	15D4G9
3	CR9500B100A3A	15D4G3	12	CR9500B100A17A	15D4G11
4	CR9500B100A4A	15D4G4	13	CR9500B100A10A	15D4G10
5	CR9500B100A5A	15D4G5	14	CR9500B100A11A	15D4G11
6	CR9500B100A39A	15D4G82	15	CR9500B100A12A	15D4G12
7	CR9500B100A6A	15D4G6	16	CR9500B100A13A	15D4G13
8	CR9500B100A7A	15D4G7	17	CR9500B100A20A	15D4G89
9	CR9500B100A16A	15D4G4	18	CR9500B100A18A	15D4G20
10	CR9500B100A8A	15D4G8	19	CR9500B100A72A	15D4G73

SOLENOID, OPERATING COILS AND RESISTORS (For Forms B and AB only)

NOTE: - The solenoid is identified by the number following the letter in the IC designation.

EXAMPLE: - IC2812-B-107-B-2 requires solenoid number 2, Cat. No. CR9500B200V30A.

The resistor is identified by the number following the last letter in the IC designation.

EXAMPLE: - IC2812-B-107-B-2 requires resistor 2, Cat. No. IC9006A100G250EA1/7.

Solenoid Number	Δ Solenoid	Ref. No. 1 Operating Coil	Resistor	Resistor Ohms
2	CR9500B200V30A	15D4G81	IC9006A100G250EA1/7	250
3	CR9500B200V23A	15D4G84	IC9006A100G700EA1/6	780
4	CR9500B200V24A	15D4G61	IC9006A100G31EA1/7	31
5	CR9500B200V30A	15D4G81	-----	--
6	CR9500B200V23A	15D4G84	-----	--
7	CR9500B200V24A	15D4G61	-----	--
8	CR9500B200V12A	15D4G49	-----	--
9	*CR9500B200V23AMFP	*15D4G84MFP	-----	--
10	CR9500B200V12A	15D4G49	IC9006A100G8.6EA1/7	8.6

* Fungus proof.

Δ For list of parts see page 5.

MOUNTING PARTS FOR RESISTOR

Cat. No.	No. Req.	Description	Cat. No.	No. Req.	Description
284A371P8	1	Mounting stud	284A425P5	1	Centering washer
284A332P1	1	Porcelain bushing	284A403P6	1	Mica washer

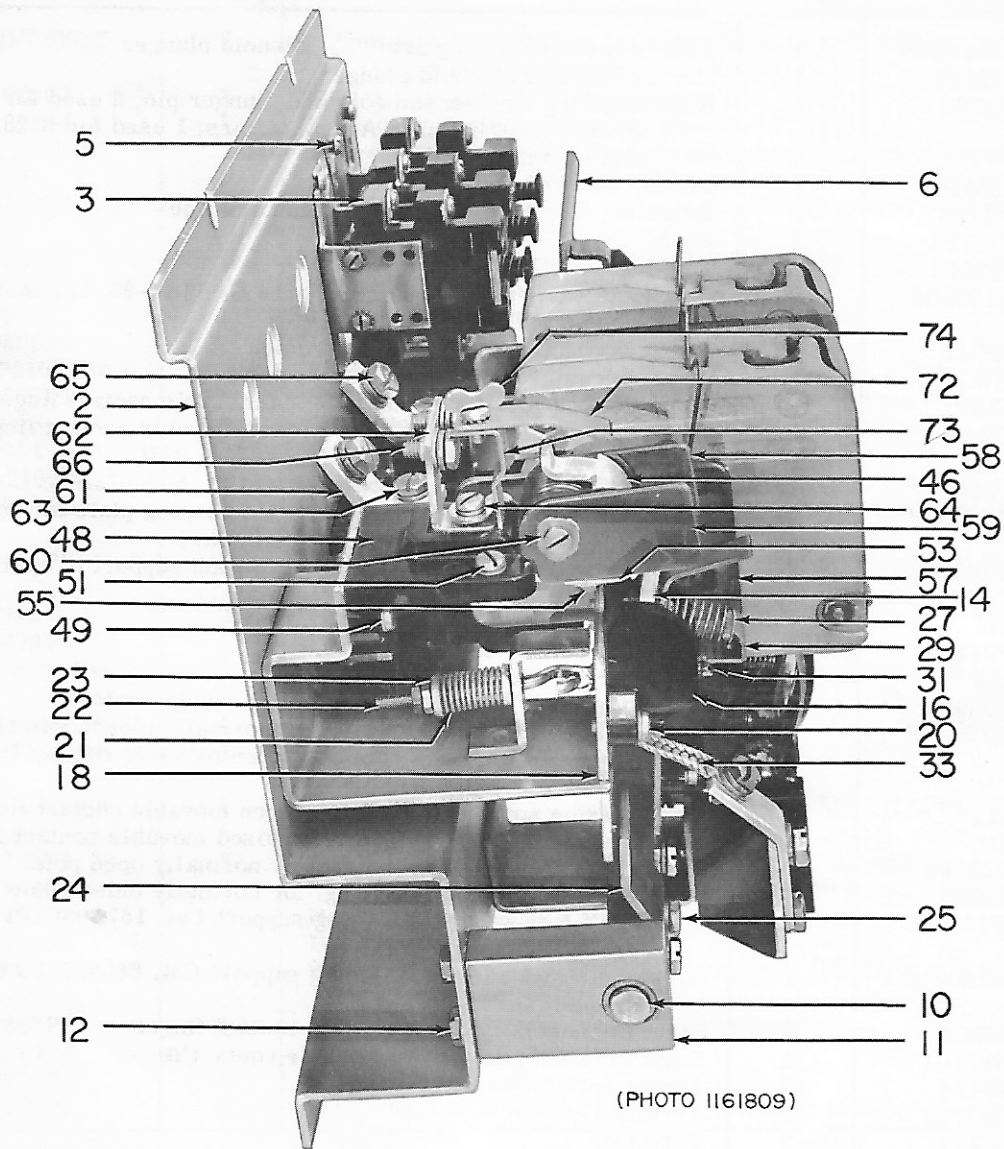

IC2812-B107A contactor (side view)

COMPLETE LIST OF PARTS

Ref. No.	Catalog Number	No. Req'd.	Description
2	977B107G1	1	Base with stop for operating arm and supports, for IC2812-B107-A and -B contactors
	977B107G2	1	Base with stop for operating arm and supports, for IC2812-B107-AA and -AB contactors
3	723B245G73	3	Interlock with bracket and mounting screws
4	IC2956A200C	3	Interlock switch unit
	6960053G3	3	Set of movable and stationary contacts with springs and contact-holding screws
5	576A145P3	6	Screw fastening interlock to base
6	117A7939G1	1	Operating arm for interlocks
	144A1306P1	1	Insulation for operating arm, for IC2812-B107-B and -AB contactors only
	N108P13006B6	2	Screw, fastening insulation to operating arm, for IC2812-B107-B and -AB contactors only
7	N22P21016B6	2	Screw, fastening operating arm to shaft (1/4 in., 20, 1 in. hex. hd., pro. fin.)

Ref. No.	Catalog Number	No. Req'd.	Description
8	144A1350P1	1	Link between operating arm and solenoid plunger
	144A1351P1	1	Pin for link and solenoid plunger
	N910P37B6	-	Retaining ring for link and solenoid plunger pin, 2 used for IC2812-B107-A, and -AA contactors; 1 used for IC2812-B107-B, and -AB contactors
9	144A1351P2	1	Pin for link and operating arm
	N910P25B6	2	Retaining ring for link and operating arm pin
10	117A7927P1	1	Shaft
11	117A7926G1	2	Bearing block for shaft
12	N22P21008B6	2	Screw fastening bearing block to base (1/4 in. -20, 1/2 in. hex. hd., pro. fin.)
13	8067076G2	2	Movable contact finger, normally open
14	8067076G1	1	Movable contact finger, normally closed
15	973C530P1	2	Insulation support for normally open movable contact finger
16	8650873P1	1	Insulation support for normally closed movable contact finger
17	117A7946P2	2	Operating plate for insulation support Cat. 973C530P1
18	117A7944G1	1	Operating plate for insulation support Cat. 8650873P1
19	N44P16008B6	4	Screw fastening insulation support to operating plate for normally open pole (10-32, 1/2 in. fill. hd., pro. fin.)
20	N144P16010C	2	Screw with lock washer fastening insulation support to operating plate, for normally closed pole
21	2416475	1	Tension spring for operating plate
22	117A7942P2	1	Adjusting rod for tension spring
23	1450952	2	Spring seat for tension spring
24	117A7950P1	1	Operating lever for normally closed movable contact
25	N22P21008B6	6	Screw fastening operating lever for normally closed movable contact or operating plate for normally open movable contact to shaft (1/4 in. -20, 1/2 in. hex. hd., pro. fin.)
26	2416475	2	Compression spring for normally open movable contact finger
27	2418818	1	Compression spring for normally closed movable contact finger
28	167A9801P1	2	Support for compression spring, for normally open pole
29	8650870P3	1	Support for compression spring, for normally closed pole
30	N144P16006C	2	Screw with lock washer fastening support Cat. 167A9801P1 to insulation support
31	N144P16004C	1	Screw with lock washer fastening support Cat. 8650870P3 to insulation support
32	8068689G1	2	Shunt for normally open movable contact finger
33	117A7921G1	1	Shunt for normally closed movable contact finger
34	8087234P4	2	Arcing horn
35	125A5936G1	1	Terminal block
36	8616562P1	2	Terminal
37	125A6050P1	1	Terminal
	N57P16008B	3	Screw fastening terminal to terminal block (10-32, 1/2 in., pan hd., pro. fin.)
38	N57P16014B6	2	Screw fastening terminal block (10-32, 7/8 in., pan hd., pro. fin.)
	125A6050P2	1	Connection strip for terminal block
40	117A7940P1	1	Connection strip for shunt, for normally closed pole
41	N26P23010B6	7	Screw fastening connection strip and arcing horn to terminal; shunt to connection strip or connection screw for terminal (5/16 in. -18, 5/8 in. hex. hd. slot, pro. fin.)
44	N22P21008B6	1	Screw fastening shunt to connection (1/4 in. -20, 1/2 in. hex. hd. slot, pro. fin.)
45	8087233G1	2	Blowout coil with support, for normally open pole
46	9043373G3	1	Blowout coil with support, for normally closed pole
47	9138877P1	2	Insulation contact support, for normally open pole for IC2812-B107-A and -B contactors only
	129B5643P1	2	Insulation contact support, for normally open pole for IC2812-B107-AA and -AB contactors only
48	9043374P1	1	Insulation contact support, for normally closed pole
	N144P21012	4	Screw with lock washer fastening contact support Cat. 9138877P1 to base
	N26P21012B6	4	Screw fastening contact support Cat. 129B5643P1 to base (1/4-20, 3/4 in. hex. hd. slot, pro. fin.)
49	N144P16010C	2	Screw with lock washer fastening contact support Cat. 9043374P1 to base
50	N144P16010C	4	Screw with lock washer fastening blowout coil support to insulation support, for normally open pole

Ref. No.	Catalog Number	No. Req'd.	Description
51	N144P16008C	2	Screw with lock washer fastening blowout coil support to insulation support for normally closed pole
52	8067063G1	2	Stationary contact, normally open
53	6973075G1	1	Stationary contact, normally closed
54	N26P23010B6	2	Screw fastening normally open stationary contact to support (5/16 in. -18, 5/8 in. hex. hd. slot, pro. fin.)
55	9384190P1	1	Screw with lock washer fastening normally closed stationary contact to support
56	8067064G1	2	Pole piece with core for normally open pole
57	8089291P2	2	Pole piece, for normally open pole
58	8650868G1	1	Pole piece with core for normally closed pole
59	8650868P4	1	Pole piece, for normally closed pole
60	N51P21012B6	2	Screw fastening pole piece to core (1/4 in. -20, 3/4 in. flat hd., pro. fin.)
	9189550P1	1	Screw with lock washer fastening pole piece to core
	5354916	2	Insulation tube for core, for normally open pole
	9023914	1	Insulation tube for core, for normally closed pole
	138A2199P1	4	Insulation between pole piece and blowout coil, for normally open pole
	9043375P1	1	Insulation between left-hand pole piece and blowout coil, for normally closed pole
	9043375P2	1	Insulation between right-hand pole piece and blowout coil, for normally closed pole
61	9092395	2	Terminal for blowout coil
62	8650872P7	1	Terminal for blowout coil
63	N22P21016B6	2	Screw fastening terminal Cat. 9092395 to support (1/4 in. -20, 1 in. hex. hd., pro. fin.)
64	N144P16008C	1	Screw with lock washer fastening terminal Cat. No. 8650872P7 to support
65	N26P23010B6	2	Connection screw for terminal Cat. 9092395 (5/16 in. -18, 5/8 in. hex. hd. slot, pro. fin.)
66	N22P21008B6	1	Connection screw for terminal Cat. 8650872P7 (1/4 in. -20, 1/2 in. hex. hd. slot, pro. fin.)
67	8244169P1	2	Arc chute side, right-hand for normally open pole
68	8244169P2	2	Arc chute side, left-hand for normally open pole
	9092730	2	Retaining spring for arc chute
69	8050866P1	2	Burning ring
70	N57P16024B	4	Screw fastening arc chute sides together (10-32, 1 1/2 in. pan hd., pro. fin.)
71	8650867P1	1	Arc chute, complete, for normally closed pole
72	8650870P6	1	Retainer for arc chute
73	8650870P5	1	Support for retainer
74	9693202P1	1	Screw with lock washer fastening retainer to support

SOLENOID

	9756581P1	1	Retainer for operating coil
75	9723645G1	1	Magnet frame
76	9723646G1	1	Plunger
77	5757027P1	2	Bracket for magnet frame
78	277A662P2	2	Screw fastening brackets to magnet frame (used on IC2812-B107-A and IC2812-B107-AA Contactors)
	277A662P5	2	Screw fastening brackets to magnet frame (used on IC2812-B107-B and IC2812-B107-AB Contactors)
79	9644951P1	2	Supporting bracket for solenoid
80	277A662P8	2	Screw fastening supporting brackets to magnet frame
	541A956P2	4	Lock nut
	541A522P18	2	Washer for screw
81	N112P16008B	4	Thread-cutting screw fastening solenoid supporting bracket to base (10-32, 1/2 in. pan hd., pro. fin.)
	281A851G2	1	Cut-out switch (used on IC2812-B107-B and IC2812-B107-AB Contactors)
	543A593G1	1	Operating rod (used on IC2812-B107-B and IC2812-B107-AB Contactors)

IC2812-B107 SYNCHRONOUS MOTOR FIELD CONTACTORS

PLAIN WASHERS

Catalog Number	Description
N402P2	For No. 1 screw
N402P9B6	For No. 10 screw
N402P11B6	For 1/4 in. screw
N403P16	For No. 8 screw

LOCK WASHERS

Catalog Number	Description
N405P39B	For No. 10 screw
N405P41B6	For 1/4 in. screw
N405P42B	For 5/16 in. screw

NUTS

Catalog Number	Description
N203P21B	1/4 in.-20, hex. std
N210P16B6	10-32 hex. std

INDEX OF CATALOG NUMBERS

Catalog identifications in this index are arranged in order, reading from *left to right*, first alphabetically according to the prefix letter or letters, if used, and second numerically.

In this index all numbers with a letter prefix will precede those without prefixes.

The number of letters or digits does not affect placement in the table, thus A1999999 will precede A2, and ZZ9999999 will precede Cat. No. 1 (number without a prefix). Letters take precedence over numbers so that Cat. No. 26F1 will precede Cat. No. 261.

Catalog Number	Page	Catalog Number	Page	Catalog Number	Page	Catalog Number	Page
CR9500B100A10A	2	N26P21012B6	4	15D4G2	2	8050866P1	5
CR9500B100A11A	2	N26P23010B6	4,5	15D4G20	2	8067063G1	2,5
CR9500B100A12A	2	N402P11B6	6	15D4G3	2	8067064G1	5
CR9500B100A13A	2	N402P2	6	15D4G4	2	8067076G1	2,4
CR9500B100A16A	2	N402P9B6	6	15D4G49	2	8067076G2	2,4
CR9500B100A17A	2	N403P16	6	15D4G5	2	8068689G1	2,4
CR9500B100A18A	2	N405P39B	6	15D4G6	2	8087233G1	4
CR9500B100A2A	2	N405P41B6	6	15D4G61	2	8087234P4	4
CR9500B100A20A	2	N405P42B	6	15D4G7	2	8089291P2	5
CR9500B100A3A	2	N44P16008B6	4	15D4G73	2	8244169P1	2,5
CR9500B100A39A	2	N51P21012B6	5	15D4G8	2	8244169P2	2,5
CR9500B100A4A	2	N57P16008B	4	15D4G81	2	8616562P1	4
CR9500B100A5A	2	N57P16014B6	4	15D4G82	2	8650867P1	2,5
CR9500B100A6A	2	N57P16024B	5	15D4G84	2	8650868G1	5
CR9500B100A7A	2	N910P25B6	4	15D4G84MFP	2	8650868P4	5
CR9500B100A72A	2	N910P37B6	4	15D4G89	2	8650870P3	4
CR9500B100A8A	2	117A7921G1	2,4	15D4G9	2	8650870P5	5
CR9500B100A9A	2	117A7926G1	4	167A9801P1	4	8650870P6	5
CR9500B200V12A	2	117A7927P1	4	2416475	2	8650872P7	5
CR9500B200V23A	2	117A7939G1	3	2416475	4	8650873P1	4
CR9500B200V23AMFP	2	117A7940P1	4	2418818	2,4	9023914	5
CR9500B200V24A	2	117A7942P2	4	277A662P2	5	9043373G3	4
CR9500B200V30A	2	117A7944G1	4	277A662P5	5	9043374P1	4
IC2956A200C	3	117A7946P2	4	277A662P8	5	9043375P1	5
IC9006A100G250EA1/7	2	117A7950P1	4	281A851G2	5	9043375P2	5
IC9006A100G31EA1/7	2	125A5936G1	4	284A332P1	2	9092395	5
IC9006A100G700EA1/6	2	125A6050P1	4	284A371P8	2	9092730	5
IC9006A100G8.6EA1/7	2	125A6050P2	4	284A403P6	2	9138877P1	4
N108P13006B6	3	129B5643P1	4	284A425P5	2	9189550P1	5
N112P16008B	5	138A2199P1	5	5354916	5	9384190P1	5
N144P16004C	4	144A1306P1	3	541A522P18	5	9644951P1	5
N144P16006C	4	144A1350P1	4	541A956P2	5	9693202P1	5
N144P16008C	5	144A1351P1	4	543A593G1	5	9723645G1	5
N144P16010C	4	144A1351P2	4	5757027P1	5	9723646G1	5
N144P21012	4	1450952	4	576A145P3	3	973C530P1	4
N203P21B	6	15D4G10	2	6960053G3	2,3	9756581P1	5
N210P16B6	6	15D4G11	2	6973075G1	2,5	977B107G1	3
N22P21008B6	4,5	15D4G12	2	723B245G73	3	977B107G2	3
N22P21016B6	3,5	15D4G13	2				

GENERAL ELECTRIC COMPANY
INDUSTRIAL CONTROL PRODUCTS DEPARTMENT
SALEM, VA. 24153

GENERAL  ELECTRIC