



GEF-6051

# RENEWAL PARTS

## DS303A7 HEAVY DUTY DC CONTACTOR

DS303A7 A01 AX A002 XF

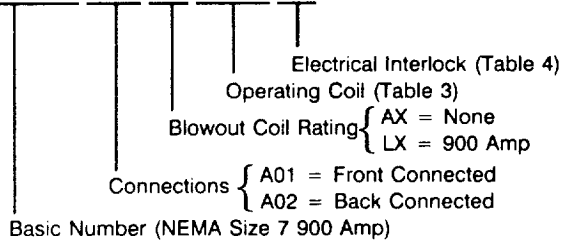
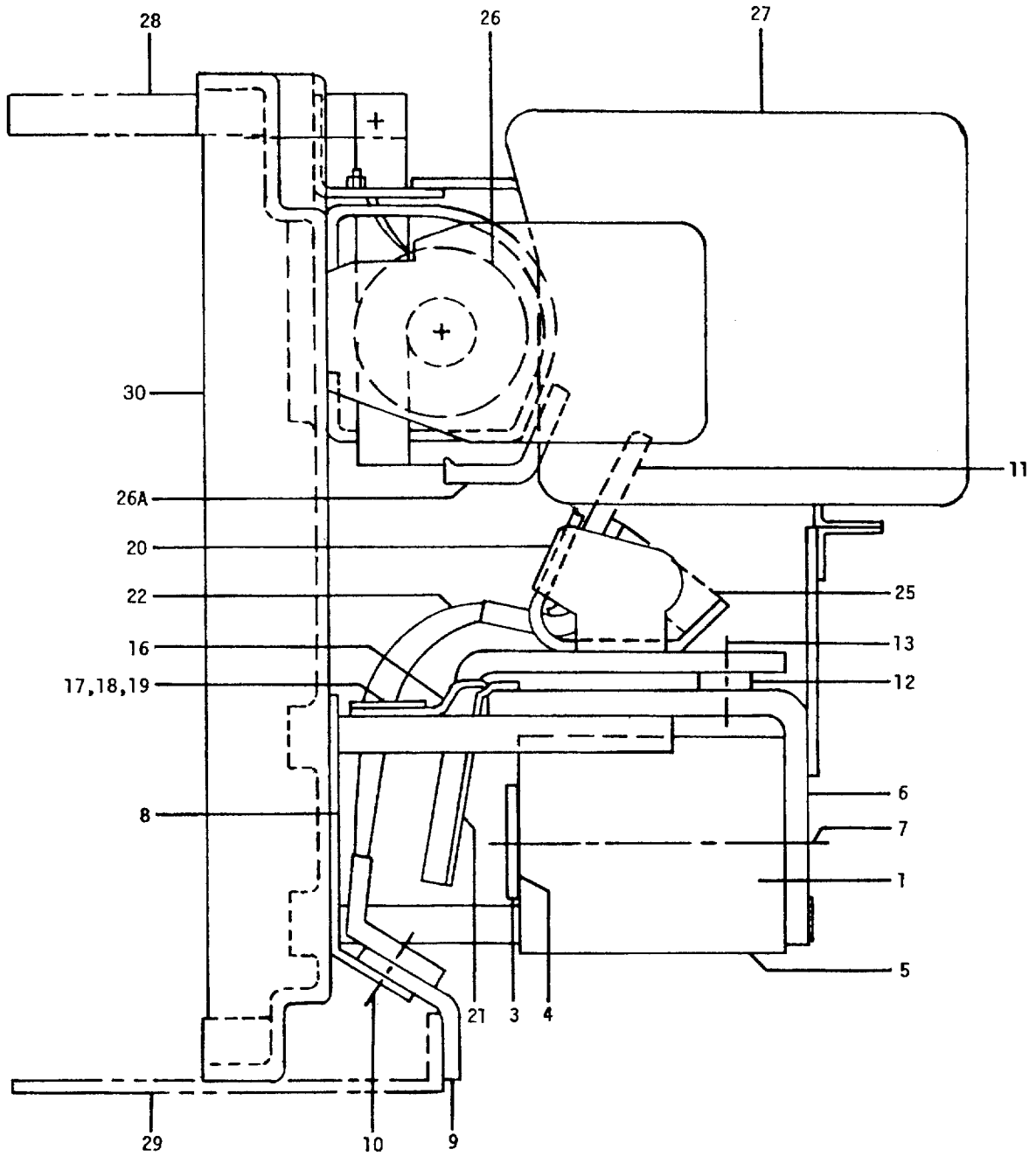

Table 1

PARTS RECOMMENDED FOR NORMAL STOCK

Ref. No.	Quantity Required		Catalog Number	Description
	Front Conn.	Back Conn.		
1	1	1	-----	Operating coil (see table 3)
	Δ	Δ	-----	Set of interlock contacts (see table 4)
11	1	1	273A2425P1	Movable contact tip
26A	1	1	259A5562G1	Stationary contact tip
22	1	1	171B3805G2	Shunt for movable contact
25	1	1	259A5572P1	Compression spring for movable contact
	1	1	171C3019G1	Arc chute, complete

Δ Quantity variable



Parts Location Diagram, DS303A7 Contactor

Table 2  
COMPLETE LIST OF PARTS

Ref. No.	Quantity Required		Catalog Number	Description
	Front Conn.	Back Conn.		
3	1	1	8626009P4	Retaining washer for coil
4	AR	AR	147A5858P5	Shim washer (use as required to insure that coil is snug)
5	1	1	5304780G3	Magnet core for operating coil
6	1	1	8650023G2	Magnet frame for operating coil
7	1	1	N22P29016B6	Screw fastening magnet core to magnet frame (1/2-13, 1 in. hex., pro. fin.)
8	1	1	5300385P1	Connection plate for magnet frame
9	1	1	259A5553P1	Terminal for connection plate
10	1	1	N62P29020B6	Carriage bolt fastening shunt and terminal to connection plate (1/2-13, 1 1/4 in. pro.fin.)
11	1	1	273A2425P1	Movable contact tip
12	1	1	8067092P3	Stop plate for armature
13	1	1	N144P16010C6	Screw with lock washer fastening stop plate to magnet frame
14	1	1	8650024P2	Fulcrum plate for armature, stationary
15	2	2	N144P21010C6	Screw with lock washer fastening stationary fulcrum plate to magnet frame
16	2	2	8690203P2	Fulcrum retainer for movable fulcrum plate
17	2	2	8616461P1	Clamping strip for fulcrum retainer
18	2	2	N144P21010C6	Screw fastening fulcrum retainer and clamping strip to magnet frame
19	2	2	8616460P1	Dowel screw for fulcrum retainer and clamping strip
20	1	1	8087245G1	Armature with support for movable contact
21	1	1	8650025P1	Fulcrum plate for armature, movable
22	1	1	171B3805G2	Shunt for movable contact
23	1	1	8617336P1	Screw fastening shunt to movable contact
24	1	1	N402P12B6	Washer for screw (Cat. No. 8617336)
25	1	1	259A5572P1	Compression spring for movable contact
26	1	1	228B9400G1	Blowout coil asm complete with coils and stationary contact
26A	1	1	259A5562G1	Stationary contact tip
	1	1	N22P25012B6	Screw for fastening stationary contact to supt
	1	1	N405P43C6	Lockwasher for screw for stationary contact
27	1	1	171C3019G1	Arc chute complete with support, screws, nuts and washers
28	--	1	193A7900P2	Top bus for back connection
29	--	1	193A7900P1	Bottom bus for back connection
30	1	1	136C2319P1	Base

Table 3  
OPERATING COILS

Coil No.	Volts	Coil Cat. No.	Rectifier Cat. No.	Pick Up Resistor Cat. No.
A002	230/250	22D75G3A	-----	-----
A003	115/120	22D75G3A	-----	-----
A004	475/500	22D75G5A	-----	-----
A005	550	22D75G19A	-----	-----
A006	600	22D75G19A	-----	-----
A008	12	22D75G26A	-----	-----
A009	18/20	22D75G25A	-----	-----
A010	24	22D75G23A	-----	-----
A011	28	22D75G9A	-----	-----
A012	32	22D75G15A	-----	-----
A014	48/50	22D75G8A	-----	-----
A016	62/68	22D75G7A	-----	-----
A018	78	22D75G4A	-----	-----
A021	100	22D75G10A	-----	-----
A022	150	22D75G6A	-----	-----
A025	180/190	22D75G16A	-----	-----
A027	275	22D75G21A	-----	-----
A028	300	22D75G11A	-----	-----
A031	440	22D75G18A	-----	-----
A032	16	22D75G28A	-----	-----
A033	36	22D75G27A	-----	-----
A034	40	22D75G14A	-----	-----
A035	110	22D75G24A	-----	-----
A650	115 AC	22D75G10A	IC3500A403C2	-----
A651	230 AC	22D75G3A	IC3500A403C6	A100G250EA-TH
A652	460 AC	22D75G2A	IC3500A403C5	A100G750EA-TH
A653	575 AC	22D75G2A	IC3500A403C8	A100G1250EA-TH
A654	380 AC	22D75G11A	IC3500A403C5	A100G100EA-TH

Table 4  
ELECTRICAL INTERLOCKS

Int'lk Letter	Interlock Switch Unit		Mounting Kit (1 per Int'lk)	* Set of Contacts (1 per Int'lk)
	Left-hand	Right-hand		
	Cat. No.	Cat. No.	Cat. No.	Cat. No.
XF	IC2956A200A	-----	IC2956A203L	6960053G3
XG	-----	IC2956A200A	IC2956A203L	6960053G3
XH	IC2956A200C	-----	IC2956A203L	6960053G3
XJ	-----	IC2956A200C	IC2956A203L	6960053G3
XK	IC2956A200B	-----	IC2956A203L	6960053G3
XL	-----	IC2956A200B	IC2956A203L	6960053G3
XM	IC2956A200A	IC2956A200A	IC2956A203L	6960053G3
XN	IC2956A200A	IC2956A200C	IC2956A203L	6960053G3
XP	IC2956A200C	IC2956A200B	IC2956A203L	6960053G3
XR	IC2956A200C	IC2956A200B	IC2956A203L	6960053G3
XS	IC2956A200B	IC2956A200B	IC2956A203L	6960053G3
**AF	IC2956A200A	-----	IC2956A203L	6960053G3
**AG	-----	IC2956A200A	IC2956A203L	6960053G3
**AH	IC2956A200C	-----	IC2956A203L	6960053G3
**AJ	-----	IC2956A200C	IC2956A203L	6960053G3
**AK	IC2956A200B	-----	IC2956A203L	6960053G3
**AL	-----	IC2956A200B	IC2956A203L	6960053G3
**AM	IC2956A200A	IC2956A200A	IC2956A203L	6960053G3
**AN	IC2956A200A	IC2956A200C	IC2956A203L	6960053G3
**AP	IC2956A200A	IC2956A200B	IC2956A203L	6960053G3
**AR	IC2956A200C	IC2956A200B	IC2956A203L	6960053G3
**AS	IC2956A200B	IC2956A200B	IC2956A203L	6960053G3
DF	IC2956A205A	-----	IC2956A203L	6960053G24
DG	-----	IC2956A205A	IC2956A203L	6960053G24
DH	IC2956A205C	-----	IC2956A203L	6960053G24
DJ	-----	IC2956A205C	IC2956A203L	6960053G24
DK	IC2956A205B	-----	IC2956A203L	6960053G24
DK	-----	IC2956A205B	IC2956A203L	6960053G24
DM	IC2956A205A	IC2956A205A	IC2956A203L	6960053G24
DN	IC2956A205A	IC2956A205C	IC2956A203L	6960053G24
DP	IC2956A205A	IC2956A205B	IC2956A203L	6960053G24
DR	IC2956A205C	IC2956A205B	IC2956A203L	6960053G24
DS	IC2956A205B	IC2956A205B	IC2956A203L	6960053G24

\* Includes movable and stationary contacts, springs and contact-holding screws.  
\*\* Interlock cover 136C2527P1 required

GENERAL ELECTRIC COMPANY • DRIVE SYSTEMS OPERATIONS • SALEM, VIRGINIA 24153

