

# RENEWAL PARTS

## DS2812-B207 SYNCHRONOUS MOTOR FIELD CONTACTORS

Forms A, AA, AB, AC, and AD

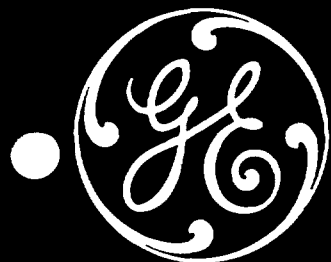

**NOTE:**—When ordering parts for a form of the contactor not covered by this bulletin, give reference number, description of part, complete nameplate reading, and above bulletin (GEF) number. Do not use catalog number when form for which the parts are needed is not covered by the bulletin.

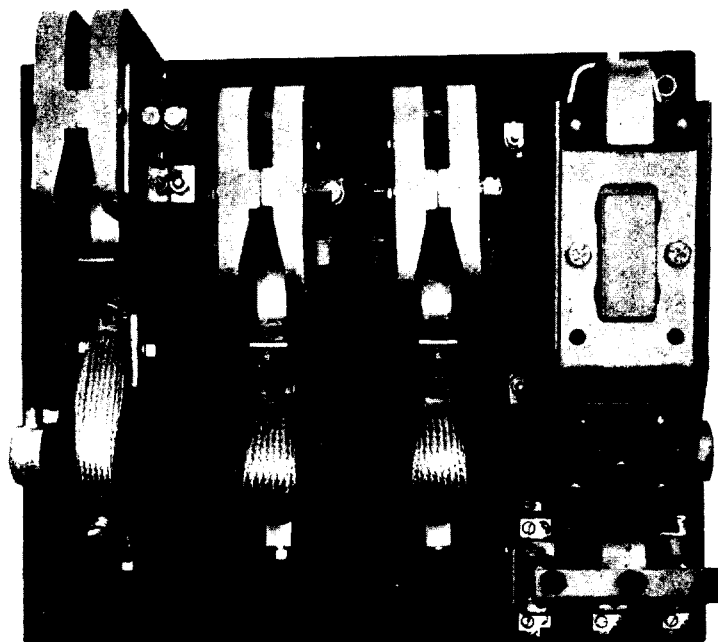

### PARTS RECOMMENDED FOR NORMAL STOCK

Ref. No.	Catalog Number	No. Req.	Description
	-----	1	Operating coil (see table page 2)
	-----	Δ	Set of interlock contacts (see table page 2)
28	288A389G2	3	Movable contact tip
29	2415140P1	2	Compression spring for movable contact tip
30	2413399P1	1	Compression spring for movable contact tip
32	3667564G1	3	Shunt for movable contact tip
42	284A948G2	1	Tension spring with support
48	3671036P2	3	Arc chute side, right-hand
	3671035P2	3	Arc chute side, left-hand
52	5306170G1	3	Stationary contact tip

Δ If interlock is used, a quantity of one set is required for each interlock.

When ordering renewal parts, give quantity, catalog number, description of each item required, and complete nameplate reading.

**GENERAL  ELECTRIC**

**DS2812-B207 SYNCHRONOUS MOTOR FIELD CONTACTORS**

OPERATING COILS - 1 Required

NOTE: The operating coil is identified by the last number in the IC designation.

EXAMPLE: DS2812-B207-A-12 requires operating coil No. 12 Catalog Number 393B202G25.

Coil No.	Catalog Number	Coil No.	Catalog Number	Coil No.	Catalog Number	Coil No.	Catalog Number
1	393B202G17	16	393B202G19	42	393B202G33	68	393B202G29
2	393B202G18	17	393B202G35	44	393B202G43	70	393B202G10
3	393B202G19	18	393B202G15	45	Δ393B202G49	74	Δ393B202G38
4	393B202G20	19	393B202G19	46	393B202G2	79	393B202G40
5	393B202G5	20	393B202G16	47	393B202G10	83	393B202G32
6	393B202G21	21	393B202G11	48	393B202G49	87	393B202G43
7	393B202G22	22	393B202G10	49	393B202G4	89	393B202G18
8	393B202G23	24	393B202G40	50	393B202G33	94	393B202G43
9	393B202G6	25	393B202G38	51	393B202G3	100	Δ393B202G48
10	393B202G10	26	393B202G31	53	393B202G8	111	Δ393B202G28
11	393B202G24	28	393B202G3	59	393B202G27	143	Δ393B202G34
12	393B202G25	29	393B202G4	63	393B202G30	146	393B202G9
13	393B202G26	38	393B202G29	64	393B202G3	147	393B202G28
14	393B202G13	39	Δ393B202G25	66	Δ393B202G19	148	393B202G39
15	393B202G18						

Δ Connected in series with resistor unit. Catalog number of coil does not include resistor unit. When ordering use number stamped on resistor unit.

ELECTRICAL INTERLOCKS

NOTE: The interlock is identified by the letter following the coil number in the IC designation.

EXAMPLE: DS2812-B207-A-12-B uses interlock letter B Cat. No. 151A5870B.

Interlock Letter	Interlock with Mounting Parts and Operating Arm Cat. No.	Interlock Switch Unit			*Set of Auxiliary Contacts for Each Switch Unit Cat. No.
		Left-hand	Middle	Right-hand	
		Cat. No.	Cat. No.	Cat. No.	
A	151A5870A	-----	IC2956A200C	-----	6960053G3
B	151A5870B	IC2956A200B	-----	IC2956A200A	6960053G3
C	151A5870C	IC2956A200B	IC2956A200C	IC2956A200A	6960053G3
D	151A5870D	IC2956A200B	IC2956A200B	IC2956A200A	6960053G3
E	151A5870E	IC2956A200B	IC2956A200B	-----	6960053G3

\* Includes movable and stationary contacts with springs and contact holding screws.

**DS2812-B207 SYNCHRONOUS MOTOR FIELD CONTACTORS**

GEF-4339

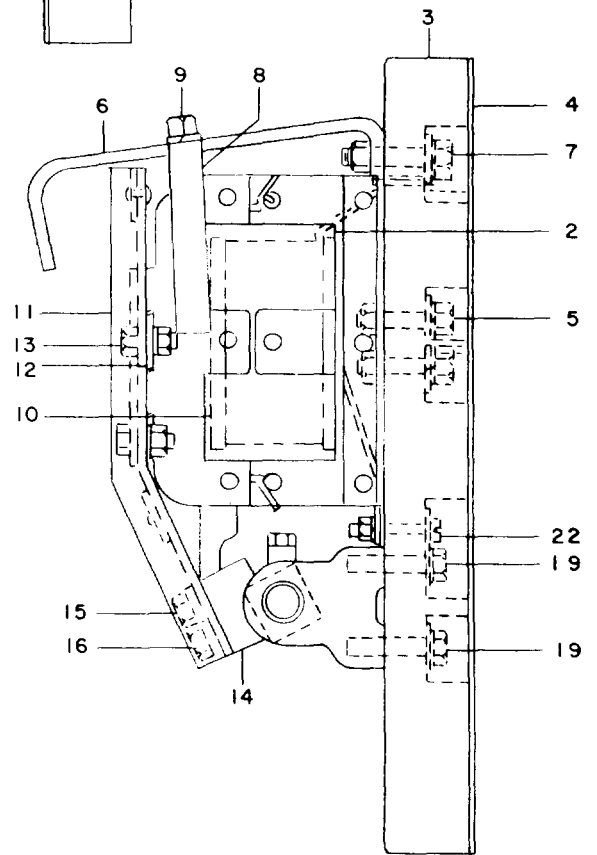
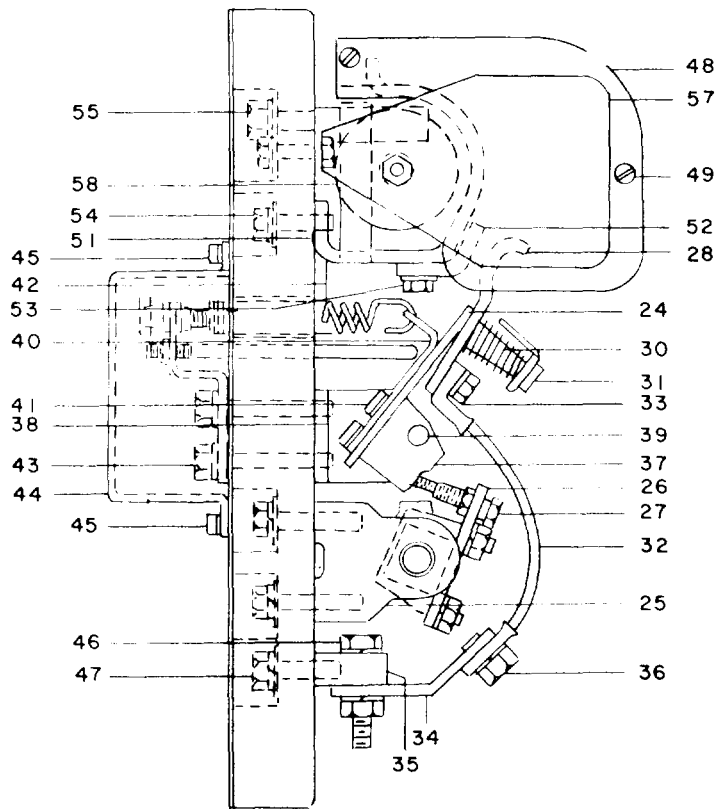
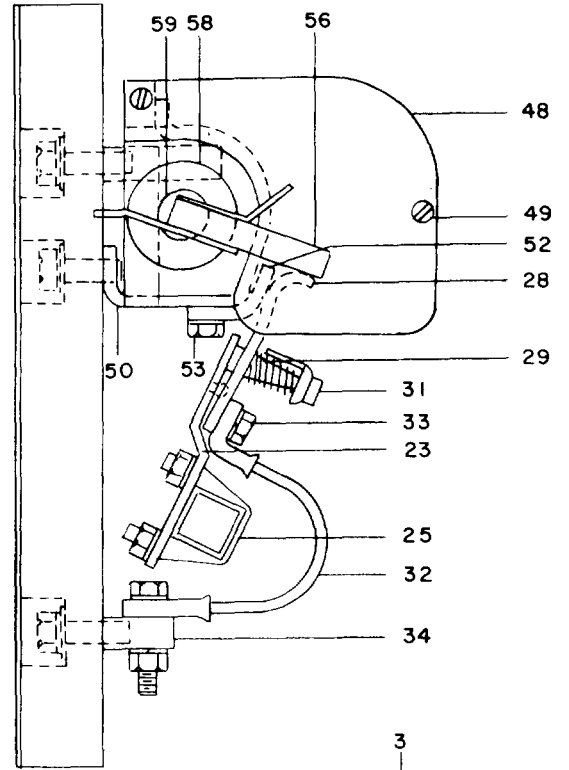
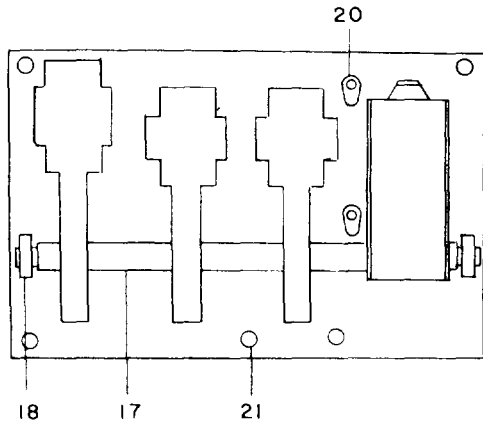

**DS2812-B207 SYNCHRONOUS MOTOR FIELD CONTACTORS**

## COMPLETE LIST OF PARTS

Ref. No.	Catalog Number	No. Req.	Description
2	3666897G1	1	Magnet frame
3	68J120202-FK01ECV	1	Base
4	151A5880P1	1	Insulation for back of base
5	N26P23020B6	2	Screw fastening magnet frame to base (5/16 in. -18, 1 1/4 in. hex. hd., pro. fin.)
6	9034898P2	1	Armature stop
7	N22P25024B6	1	Screw fastening armature stop to base (3/8 in. -16, 1 1/2 in. hex. hd., pro. fin.)
8	1470747P1	1	Retainer for operating coil
9	N26P23008B6	1	Screw fastening retainer to armature stop (5/16 in. -18, 1/2 in. hex. hd., pro. fin.)
10	2831897G2	1	Armature assembly
11	8625908G1	1	Supporting bracket for armature
12	1434649P1	1	Fulcrum for armature
13	N26P23012B6	4	Screw fastening fulcrum to armature bracket (5/16 in. -18, 3/4 in. hex. hd., pro. fin.)
14	4329978P1	1	Supporting block for armature
15	N22P25012B6	1	Screw fastening supporting block to armature (3/4 in. -16, 3/4 in. hex. hd., pro. fin.)
16	N22P25024B6	2	Screw fastening armature and supporting block to shaft (3/8 in. -16, 1 1/2 in. hex. hd., pro. fin.)
17	394B549G16	1	Insulated shaft
18	188A3638G1	2	Bearing bracket for shaft
19	N22P25020B6	4	Screw fastening bearing bracket to base (3/8 in. -16, 1 1/4 in. hex. hd., pro. fin.)
20	147A5837P1	2	Terminal
21	6922211G46	1	Terminal (for Forms AA and AB only)
22	N57P16020B6	2	Screw fastening terminal to base (10-32, 1 1/4 in., pan hd. slot., pro. fin.)
23	3845792G1	2	Support for movable contact tip
24	572A926G2	1	Support for movable contact tip
25	2437414P1	3	Yoke for contact tip support
26	5352538P1	1	Operating arm (for Form A only)
	5352538P2	1	Operating arm (for Forms AA, AB, AC and AD only)
27	5352539P1	1	Adjusting screw for operating arm
28	288A389G2	3	Movable contact tip
29	2415140P1	2	Compression spring for movable contact tip
30	2413399	1	Compression spring for movable contact tip
31	2486634P1	3	Spring seat for compression spring
32	3667564G1	3	Shunt for movable contact tip
33	N26P23008B6	3	Screw fastening shunt to movable contact tip (5/16 in. -18, 1/2 in. hex. hd., pro. fin.)
34	2473069P1	1	Shunt extension
35	576A674P1	3	Terminal post
36	N26P23008B6	1	Screw fastening shunt extension to shunt (5/16 in. -18, 1/2 in. hex. hd., pro. fin.)
37	2473067	1	Bearing block
38	2473065	1	Support for bearing block
39	5381841P1	1	Spacer for bearing block
	N26P23024B6	1	Screw fastening spacer to support (5/16 in. -18, 1 1/2 in. hex. hd., pro. fin.)
40	2473066	1	Spring finger
41	N26P23010B6	2	Screw fastening spring finger to bearing block (5/16 in. -18, 5/8 in. hex. hd., pro. fin.)
42	284A948G2	1	Tension spring with support
43	N26P23028B6	2	Screw fastening spring support to bearing block (5/16 in. -18, 3/4 in. hex. hd., pro. fin.)
44	151A5849P1	1	Cover
45	N146P15012B6	3	Screw fastening cover to base (No. 8 by 3/4 in., pan hd., thread cutting)
46	N26P23024B6	3	Screw fastening terminal post to shunt or shunt extension (5/16 in. -18, 1 1/2 in. hex. hd., pro. fin.)
47	N26P23020B6	3	Screw fastening terminal post to base (5/16 in. -18, 1 1/4 in. hex. hd., pro. fin.)
48	3671036P2	3	Arc chute side, right-hand
	3671035P2	3	Arc chute side, left-hand
49	N57P16032B6	6	Screw fastening arc chute sides together (10-32, 2 in., pan hd. slot., pro. fin.)
50	2831867G1	2	Blowout coil with connection block and support for stationary contact (for Forms A, AA, and AC only)
	2831867G4	2	Blowout coil with connection block and support for stationary contact (for Forms AB and AD only)
51	2831867G2	1	Blowout coil with connection block and support for stationary contact
52	5306170G1	3	Stationary contact tip
53	N26P23010B6	3	Screw fastening stationary contact tip to support (5/16 in. -18, 5/8 in. hex. hd., pro. fin.)
54	N22P25020B6	3	Screw fastening connection block to base (3/8 in. -16, 1 1/4 in. hex. hd., pro. fin.)
55	N26P23020B6	4	Screw fastening blowout coil to base (5/16 in. -18, 1 1/4 in. hex. hd., pro. fin.)
56	2831899G1	2	Pole piece with magnet core for blowout coil
	2831899G2	2	Pole piece for blowout coil
57	3869826P1	2	Pole piece for blowout coil
58	1444670P1	6	Insulation flange for blowout coil
59	1427781P1	2	Insulation sleeve for magnet core
	2474730P1	1	Insulation sleeve for magnet core
	2473096P1	1	Magnet core for pole piece